

Alle Rechte vorbehalten/ All rights reserved

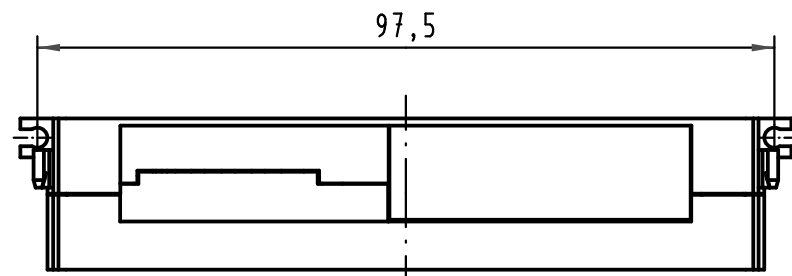

X
X
geöffnet
open

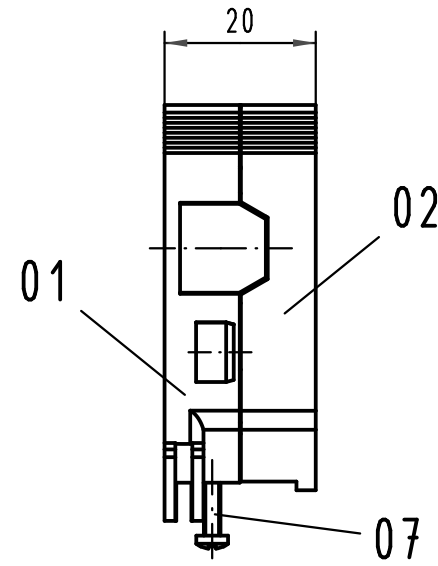
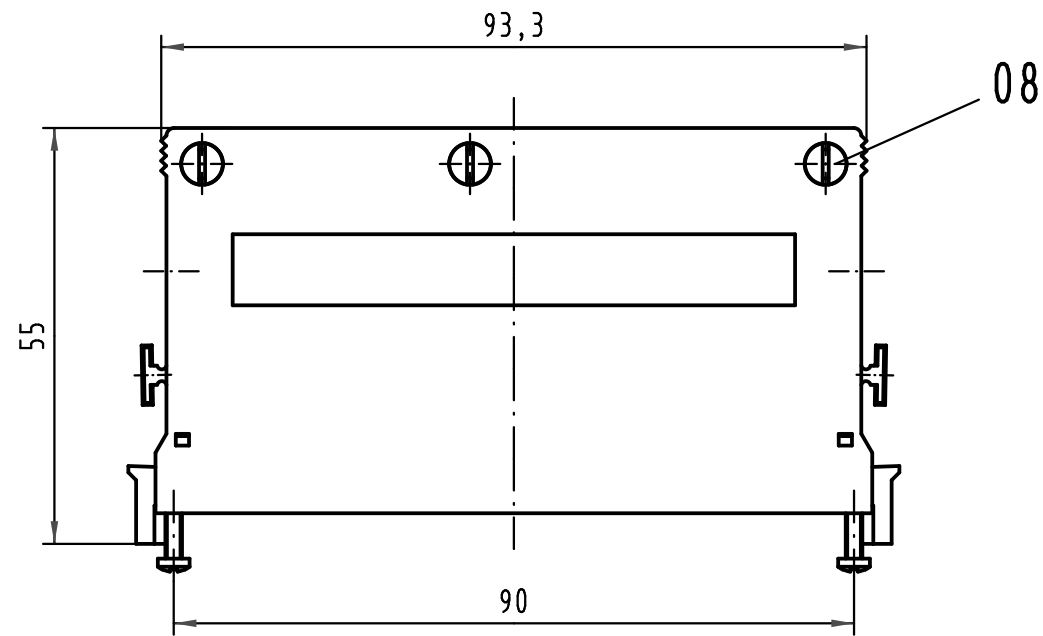
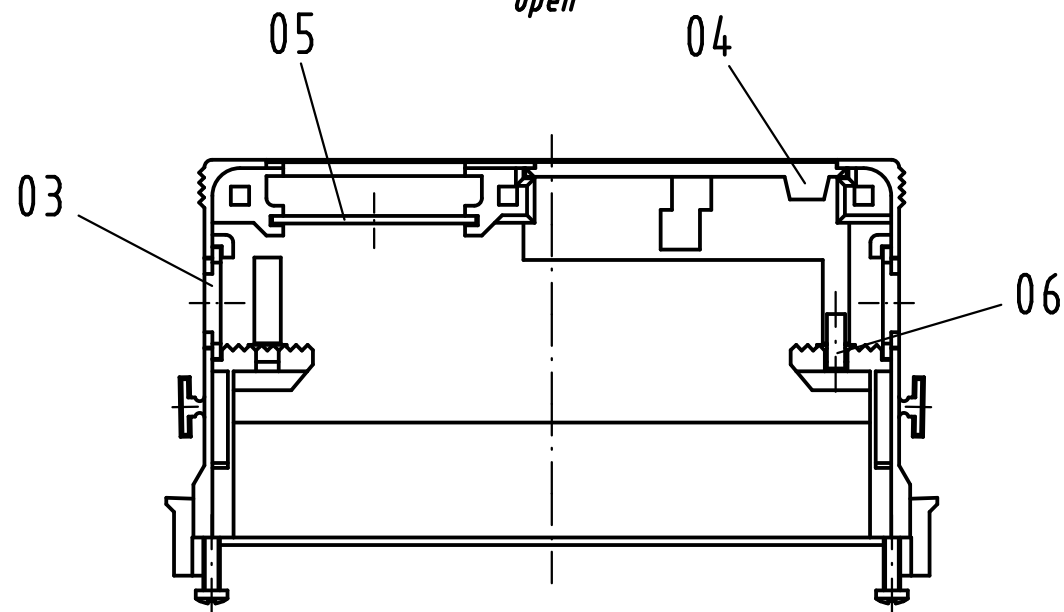

Pos. pos.	Anzahl number	Benennung description
01	1	Grundschaale shell
02	1	Deckel cover
03	2	Blindstopfen blinding piece
04	1	Verschlussplatte blinding plate
05	1	Masseblech grounding plate
06	1	Kabelbinder cable tie
07	2	Schraube ST 2,2x9,5 screw ST 2,2 x 9,5
08	3	Schraube ST 2,9x13 screw ST 2,9x13

Teile nicht montiert
parts not assembled

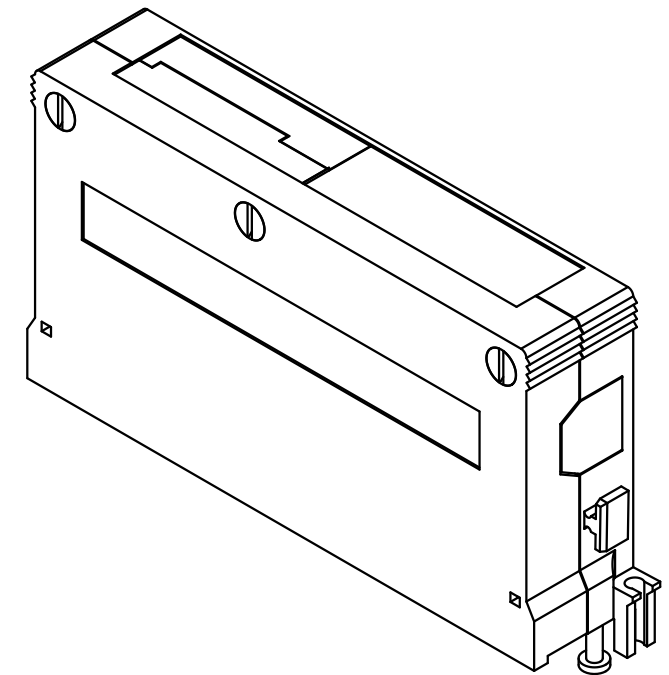

All Dimensions in mm Original Size DIN A 3		Techn. Character.			Nicht tolerierte Maß/Free size tolerances	
		Dat.	Name	Maßstab/Scale	Schalengehäuse B20 für Federleisten <i>shell housing B20</i> for female connectors	
		Detail.	02.03.07 Hage.	1:1		
		Insp.	02.03.07 LeHT			
		Stand.				
34236		HARTING Electronics GmbH & Co. KG			TB 09 05 048 0501	Blatt/page
Mod.	Dat.	Name	D-32339 ESPELKAMP	Sub.		